

Diamond Interchange Alignment Controls

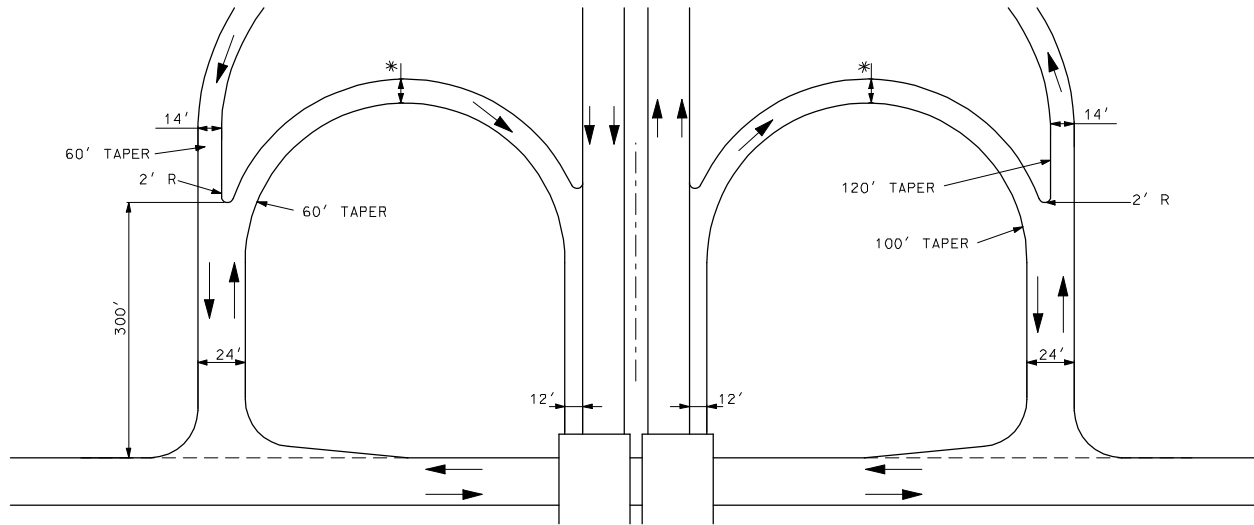

2-LANE MINOR ROAD

* 18' WHEN RADIUS IS $\geq 400'$
 * 22' WHEN RADIUS IS $< 400'$

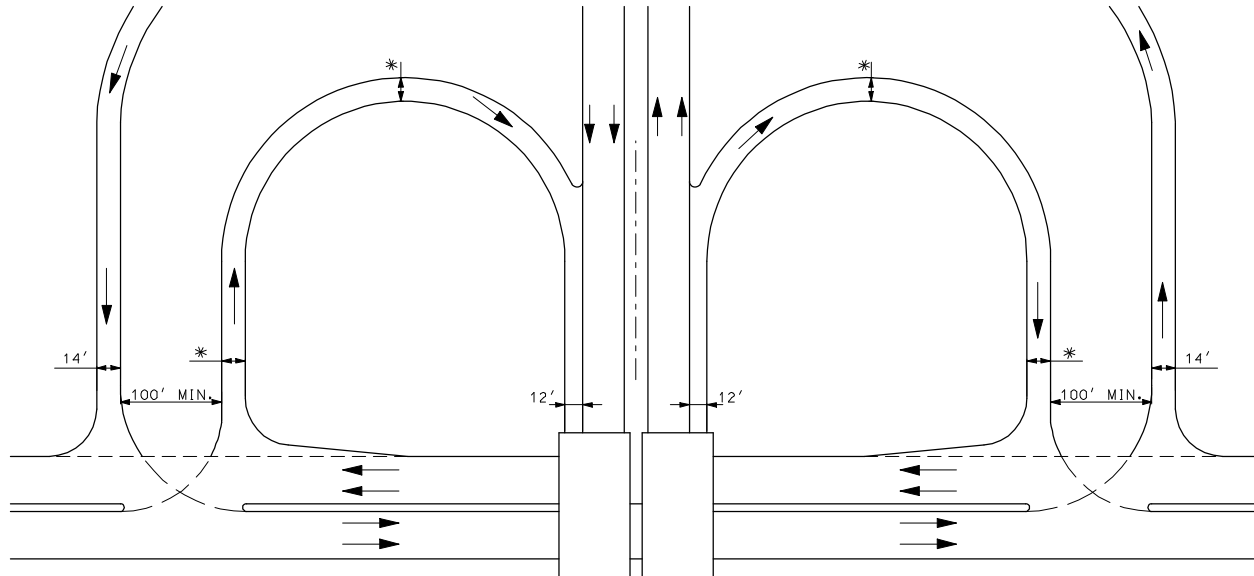

4-LANE MINOR ROAD

Folded Diamond-Type Interchange

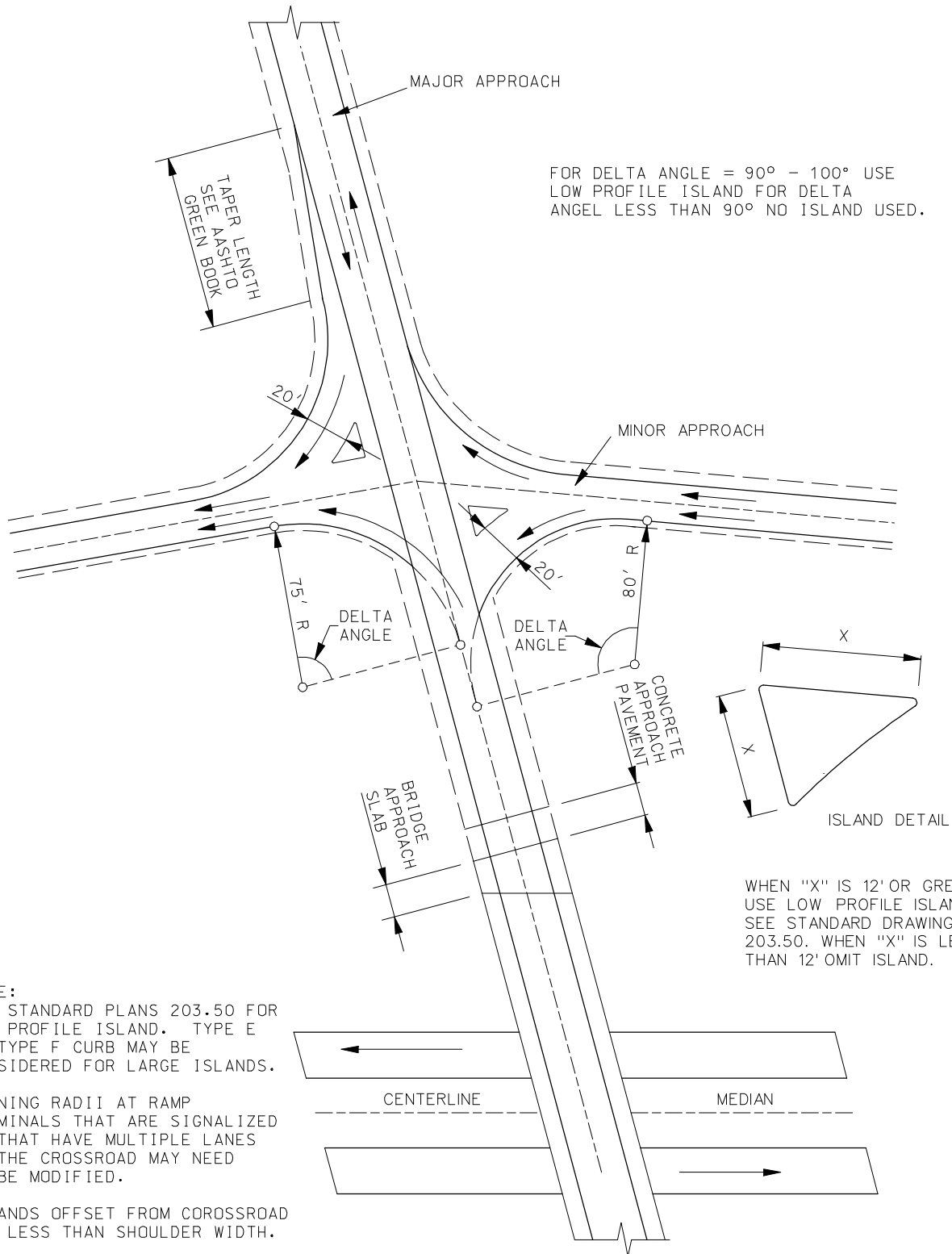

Geometries of Diamond Interchanges - Ramp Termini

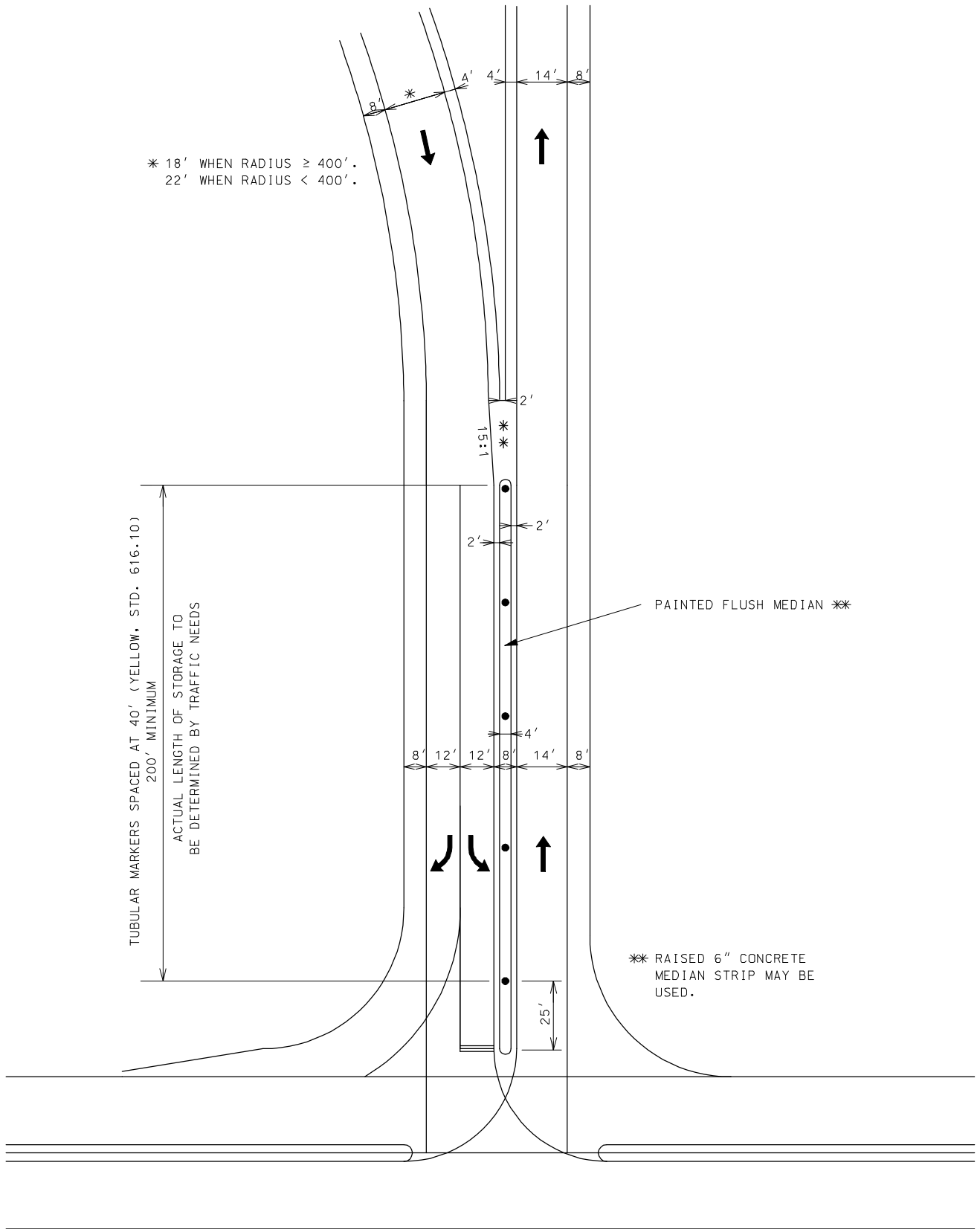

Folded Diamond Intersection Details